

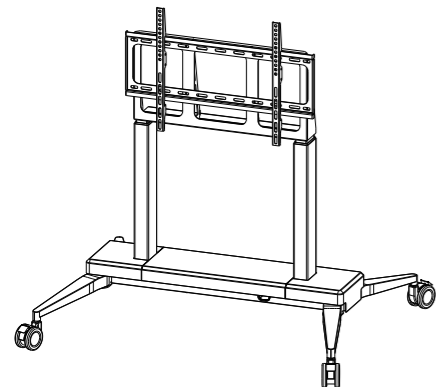

Item No.: QTS107
Installation guide



- | | | | | | |
|---------------------|---------------------------------|------------------------|-------------------------------|--------------------|--------------------|
| M6x16MM
A(12PCS) | Hex Wrench
B(1PC) | Spacer
C(4PCS) | Rectangular Washer
D(4PCS) | M4X20MM
E(4PCS) | M5X20MM
F(4PCS) |
| M6X25MM
G(4PCS) | M8X25MM
H(4PCS) | 1. Base Plate
(1PC) | 2. lifting column
(2PCS) | 3. Cover
(1PC) | |
| | 4. Mounting Back Plate
(1PC) | 5. Hanger
(2PCS) | 6. Side Cover
(2PCS) | | |
| Accessory Bag | | 7. Power Cables | Remote Control | | |



- 600X400
- Max 80kg
- 32"-70"
- 98mm

STEP 3

Install the lifting columns and the Mounting Back Plate

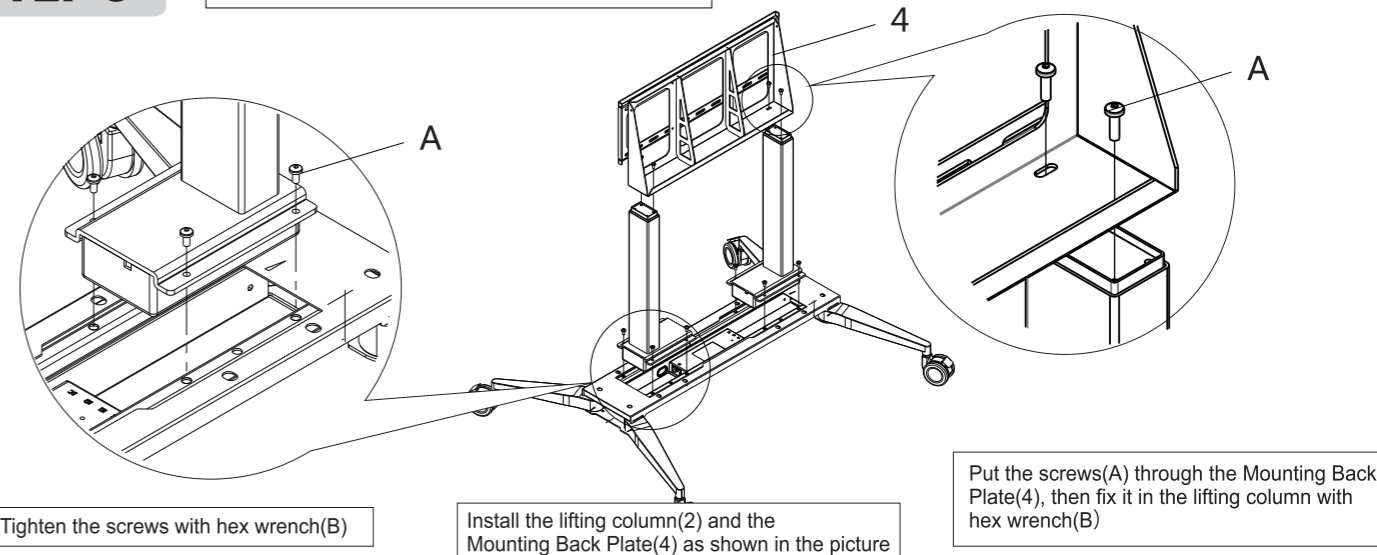

STEP 1

Unfold the footing of the base

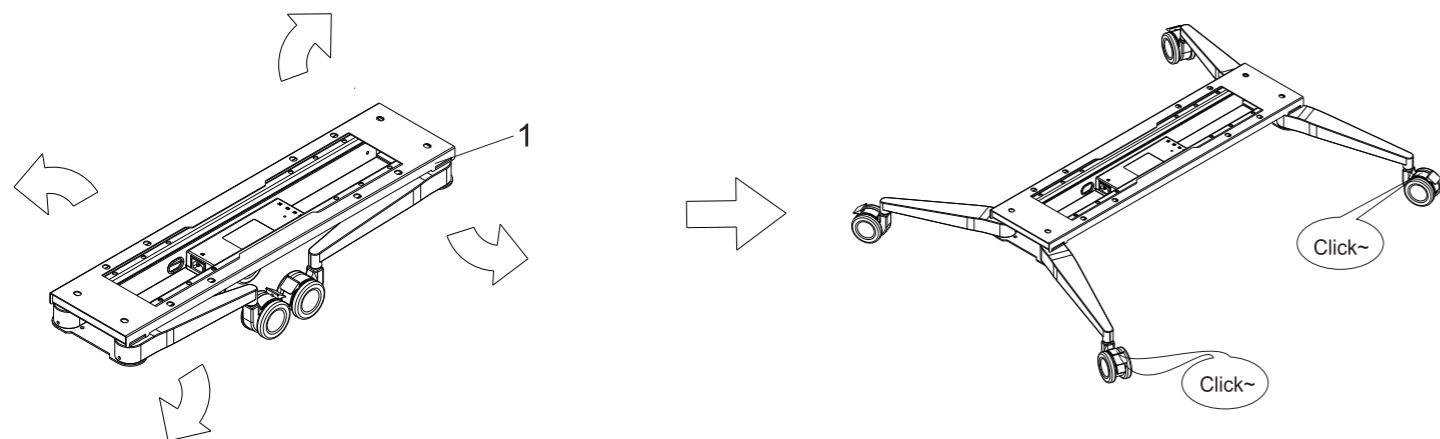

You will hear the sound of "Click" when you unfold the footing of the Base Plate(1) shown in the picture.

STEP 4

Install the cover

Please ensure you press the raised side of the cover to the lower side, and confirm the two covers are flush.

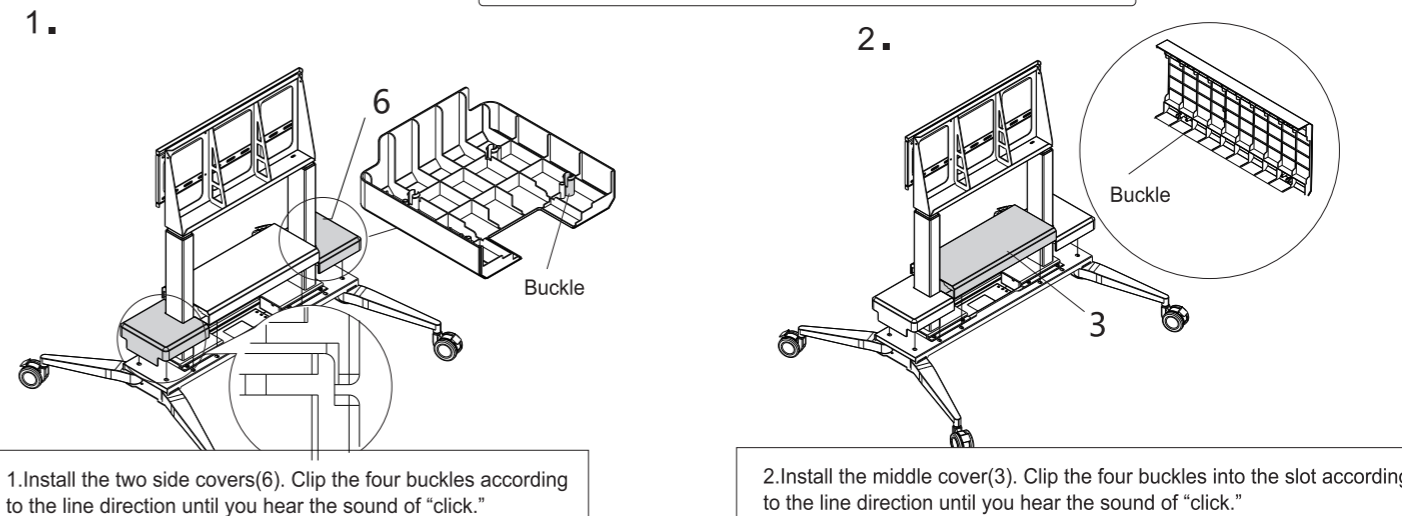

STEP 2

Connect the ports of the control box

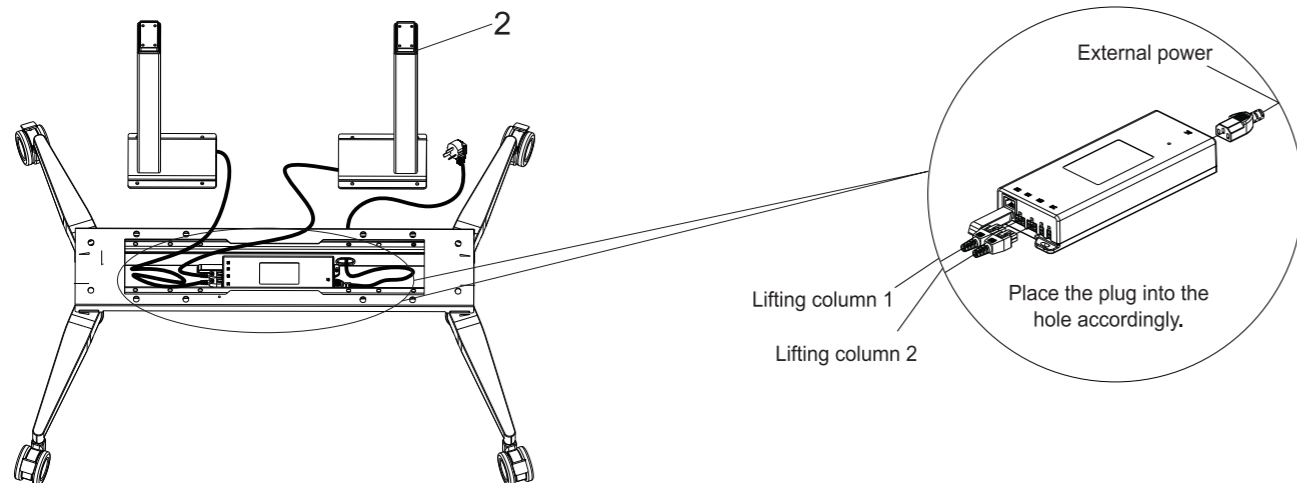

Connect Power Cables(7) in the control box as per the diagram above prior to bolting the Lifting Columns(2) in place.

STEP 5

Install TV to the wall panel

Rectangular Washer (D)

- Use for M8 screws
- Use for M5 and M6 screws
- Use for M4 screws

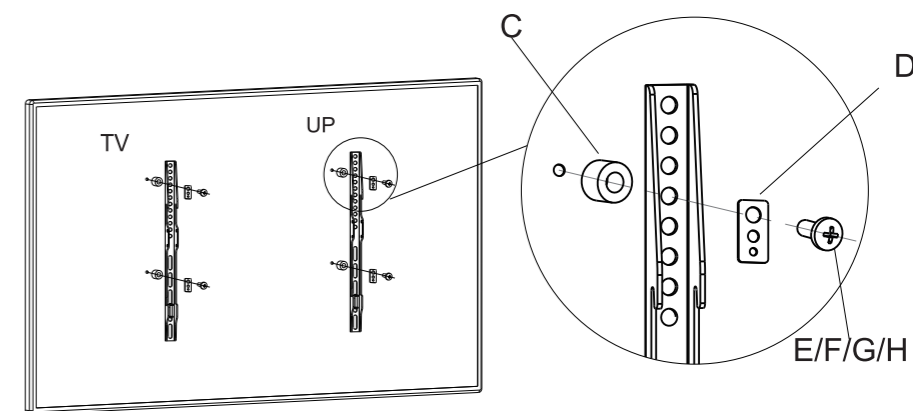

STEP 6

Install TV, switch the power on, adjust the height

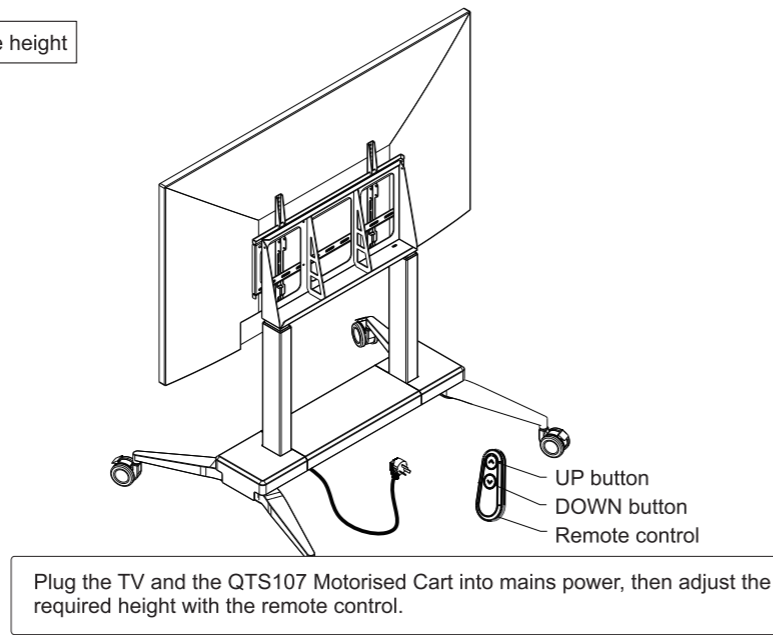
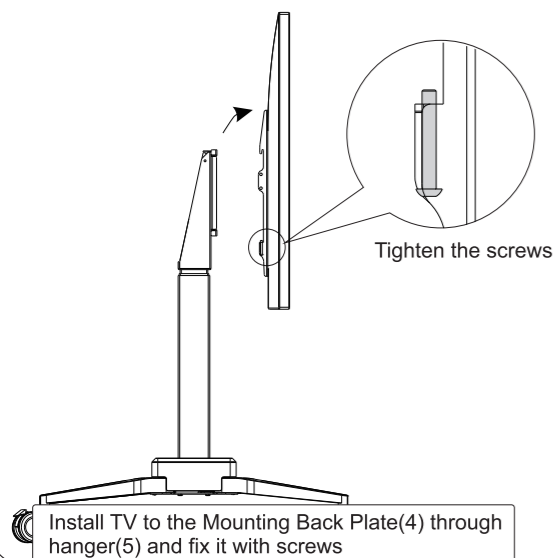

Plug the TV and the QTS107 Motorised Cart into mains power, then adjust the required height with the remote control.

How to use Remote Control

keypad

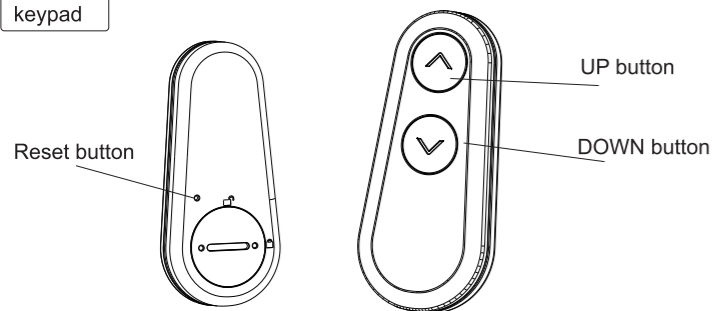

●	“▲”	UP button: adjust the height upwards
●	“▼”	DOWN button: adjust the height downwards
●	“○”	RESET button: there is a tiny hole behind the remote control, reset it with a paper clip

Operation instruction

Attention! This product needs to be shut down for 18 minutes after 2 minutes running.

● Keypad function instructions:

- 1.Touch Button Lift Function:
The height of the TV rack can be adjusted up or down by touching the UP or DOWN button.
- 2.Remote Pairing Function:
Power off over 10 seconds, power on again and press the UP and DOWN buttons simultaneously over 1 second.
- 3.If the pairing process failed, please check the connecting lines are flawless. After correct connection, power off over 10 seconds, power on again and press the UP and DOWN buttons simultaneously over 1 second. Finish the Bluetooth dongle reset process; then enter “(3) remote pairing function.”
- 4.If it still fails after performing the above operations, please contact your service personnel.

● Reset Operation:

- 1.Press the DOWN button until the TV lifting system is in the lowest position and rebound to rise and stop. Release the DOWN button to finish the reset operation and the TV lifting system can be used normally.
- 2.If other situations appear, please check the connecting lines are flawless. After properly connected, power off over 10 seconds, power on again and press the DOWN button to reset.
- 3.If it still fails after performing the above actions, please contact your service personnel.

Common fault treatment

The following tips will help you detect and eliminate common errors. If the relevant fault is not listed below, please contact your supplier. Only the manufacturer and professionals are capable of correcting these issues.

Fault phenomenon	Method
No response after pressing the down arrow for a long period of time while connected to a power supply.	1.Check if all the cables are connected well. 2.Contact your supplier or dealer
No response while pressing up arrow/ down arrow after connected with a power supply	1.Check if all the cables are connected well. 2.Contact your supplier or dealer
Rising in a low speed	1. Check if overloaded, max loading: 80kg; 2. Contact your supplier or dealer
The motor does not move as instructed	1. Contact your supplier or dealer
Goes down but not up.	1,Reposition 2,Contact your supplier or dealer
Downward sliding	1. Check if overloaded, max loading: 80kg; 2. Contact your supplier or dealer
Frequently repositions.	1. Check if overloaded, max loading: 80kg; 2. Contact your supplier or dealer
Overwork (Duty cycle: Max 2min on/18min OFF)	1. Restart after suspending for 18 mins while connecting with power; 2. Contact your supplier or dealer;
Not enough up&down height	1. Press “M”and “3” together for 3 seconds or more, after hearing continuous beeping for twice, it will restore factory settings 2,Contact your supplier or dealer



Attention

1. Power supply: AC100V-240V,50/60HZ
2. Service Environment: 0-40℃
3. Unplug the power plug before cleaning, wipe the dust off surface with slightly wet dishcloth, be careful not to let the drops into internal parts, don't lose the connector.
4. The electric box contains electronic components, metals, plastics, wires etc., so dispose of it in accordance with each country's environmental legislation, not the general household waste.
5. Check carefully to ensure correct and complete assembly before using.
6. Be familiar with all functions and program settings of the product before first use.
7. Children are forbidden to play on the product due to possible injury.
8. Slight noise caused by the V-ribbed belt or brake system due to structure will not have any effect on the use of the equipment.
9. Corrosive or abrasive materials are forbidden to clean the equipment. Must ensure that the cleaner used will not pollute the environment.
10. This appliance can be used by children aged from 8 years and above and persons with reduced physical, sensory or mental capabilities or lack of experience and knowledge if they have been given supervision or instruction concerning use of the appliance in a safe way and understand the hazards involved. Children shall not play with the appliance.
11. Cleaning and user maintenance shall not be made by children without supervision.
12. If the supply cord is damaged, it must be replaced by the manufacturer, its service agent or a similarly qualified person in order to avoid a hazard.
13. Please make sure there are no hazard sources in your operating environment e.g. do not litter tools. Always be careful to treat the packaging materials with care in order to avoid any possible danger e.g. plastic bag may lead to choking hazard for children.
14. Keep the original package of the equipment if necessary for future use in transportation.

If the remote control is lost, please download the App to control the QTS107 via bluetooth

Installation guide of the “Loctek BT Control” App

- 1.Please scan the QR code on the right with your phone, after entering the page, please click the blue font “download link” to download the “Loctek BT Control” App”.
- 2.When the download is complete, please return to the page that scans the QR code, and check the “Application Indication” to use and connect the “Loctek BT Control” App.
3. When using the App to control the QTS107, the actual height is displayed on your device in mm.



Q-Tee offers the most comprehensive range of brackets and mounts for LED/LCD/OLED and Plasma Displays. Our products are engineered to the highest quality and designed to fit VESA and Non-VESA standards to make installations quick and easy. Regardless of the application, Q-Tee has the solution to suit your requirements for both domestic and commercial applications.

Q-Tee is a registered trademark of 'Quantum Sphere Pty Ltd'.
PO Box 6077, Dural, NSW 2158, Australia

P: 1300 571 188
F: 02 8569 0655
www.qsphere.com.au

