

Maintenance

- Check that the bracket is secure and safe to use at regular intervals(at least every three months).
- Please contact your distributor if you have any questions.

INSTALLATION MANUAL

QTL09-812FW



200x200/300x300/400x200
400x400/600x400/800x400
800x600/1000x600/1000x800
1200x600/1200x800



 **Read the entire instruction manual before you start installation and assembly. If you have any questions regarding any of the instructions or warnings, please contact your local distributor for assistance.**

CAUTION

- Use with products heavier than the rated weights indicated may result in instability causing possible injury.
- Please closely follow the assembly instructions. Improper installation may result in damage or serious personal injury.
- Safety gear and proper tools must be used. This product should only be installed by professionals.
- Make sure that the supporting surface will safely support the combined weight of the equipment and all attached hardware and components.
- Use the mounting screws provided and **DO NOT OVER TIGHTEN** mounting screws.
- This product contains small items that could be a choking hazard if swallowed. Keep these items away from children.
- This product is intended for indoor use only. Using this product outdoors could lead to product failure and personal injury.

Required for Installation



Component Checklist

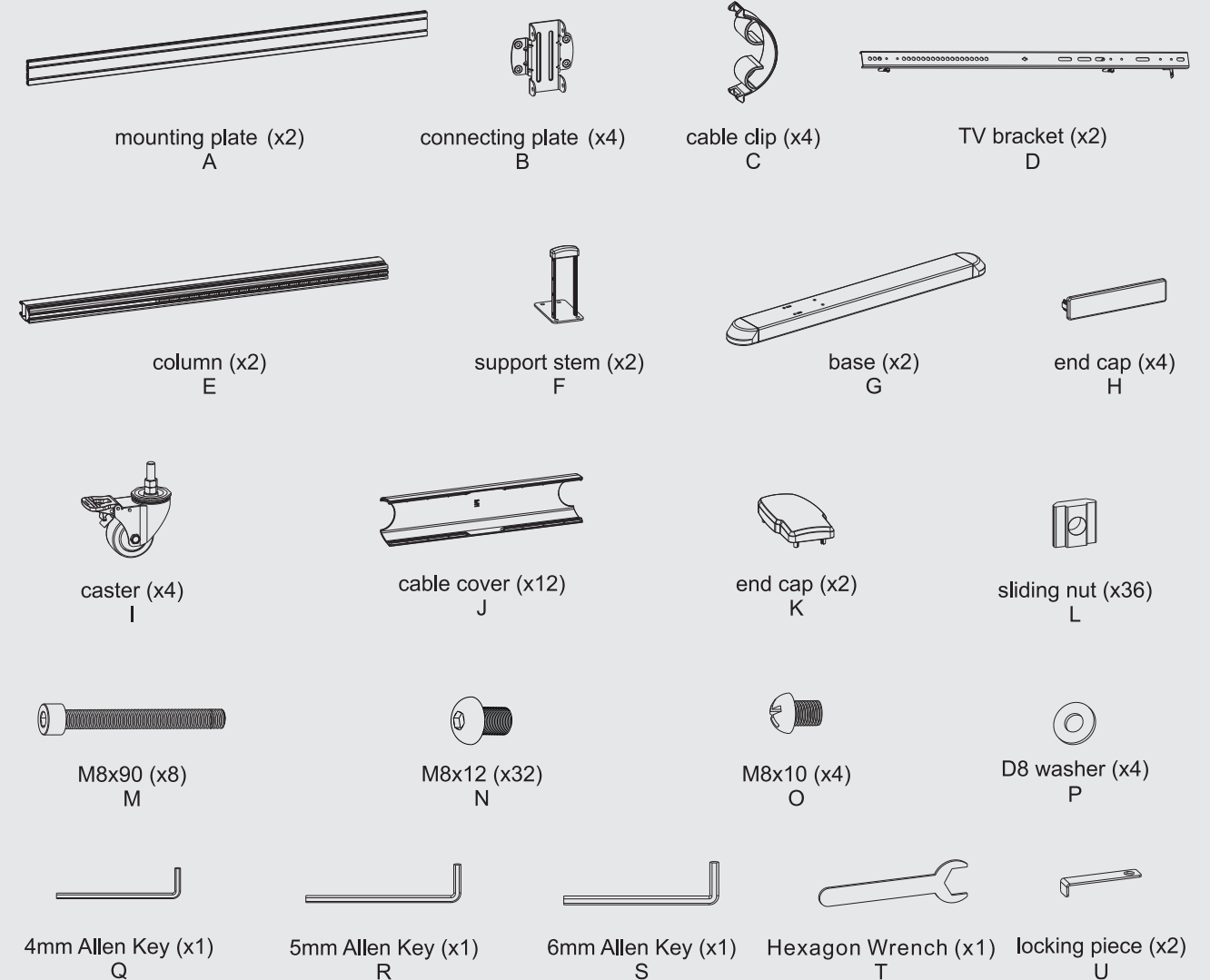

IMPORTANT: Ensure that you have received all parts according to the component checklist prior to installation. If any parts are missing or faulty, contact your place of purchase for a replacement.

Package M

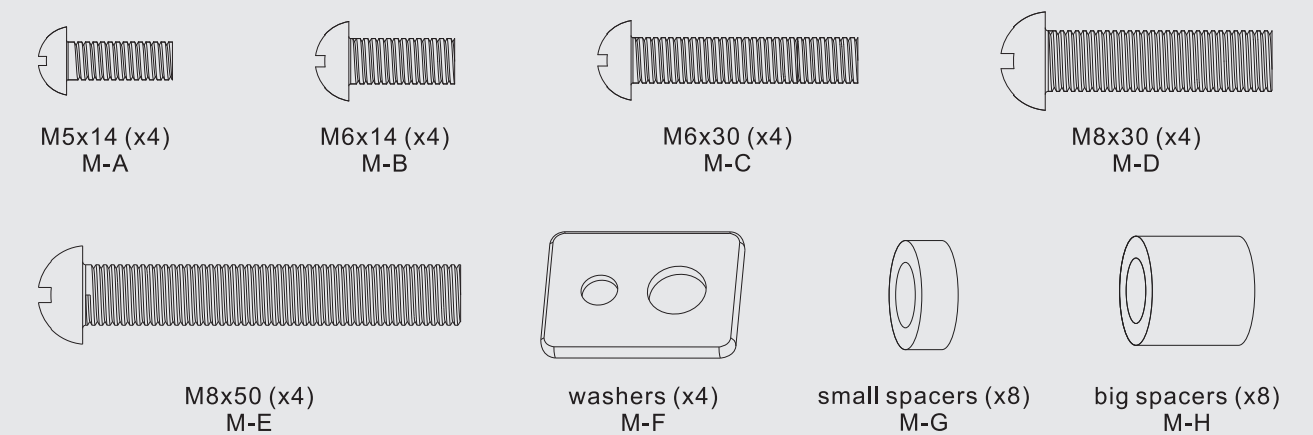

1. Attach Connecting Plate to the Column

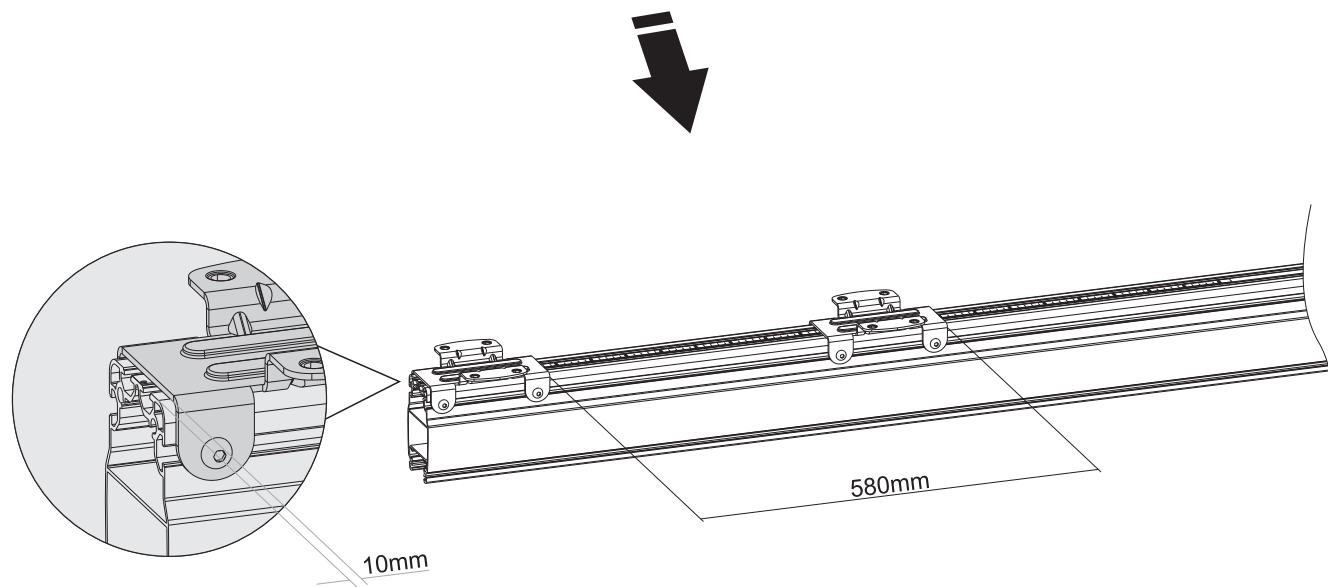
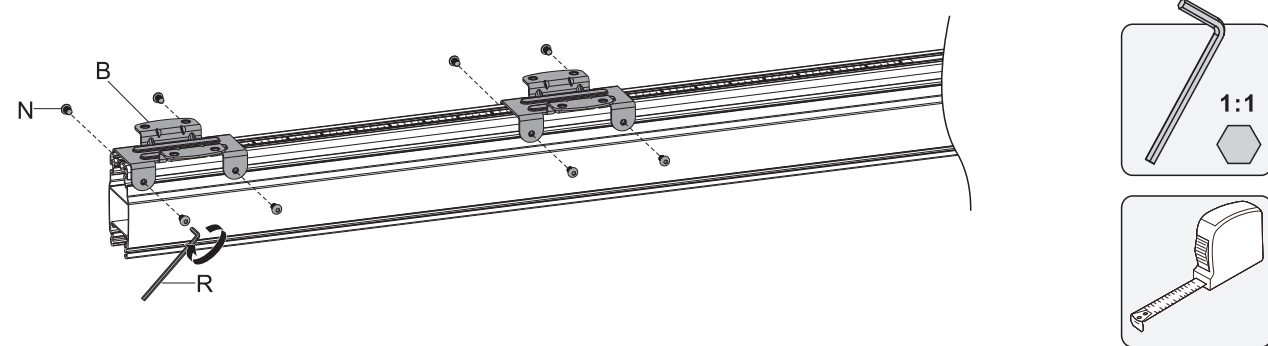
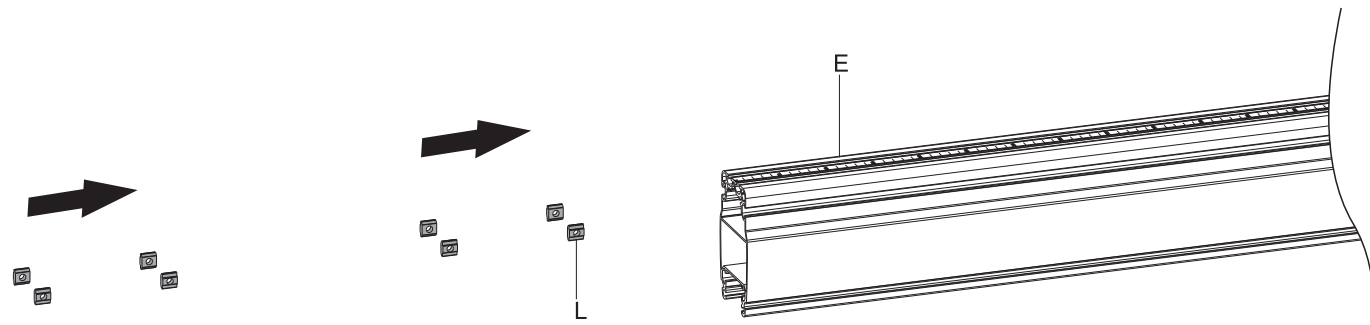

2. Attach Column to the Mounting Plate

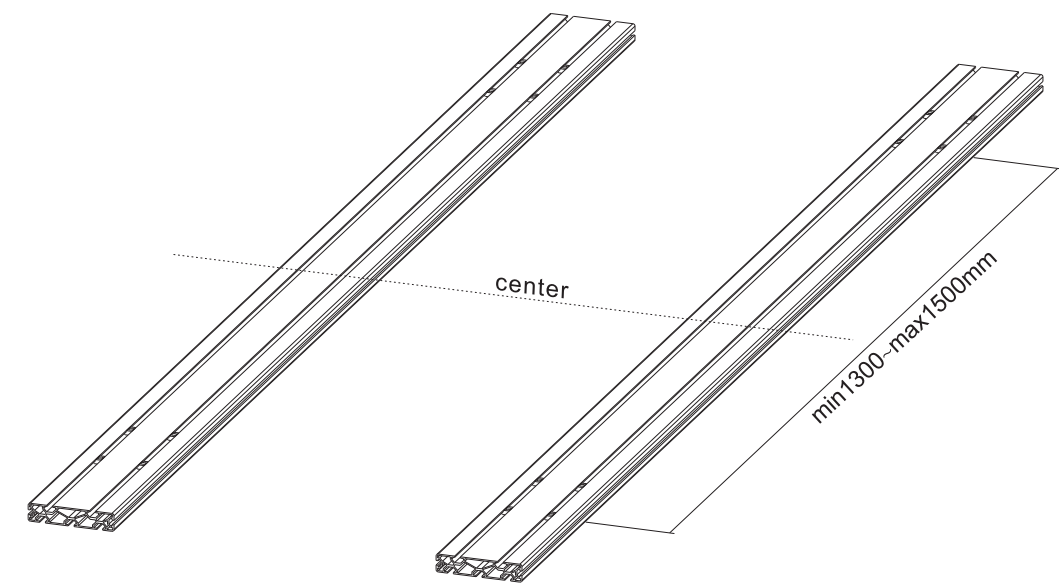
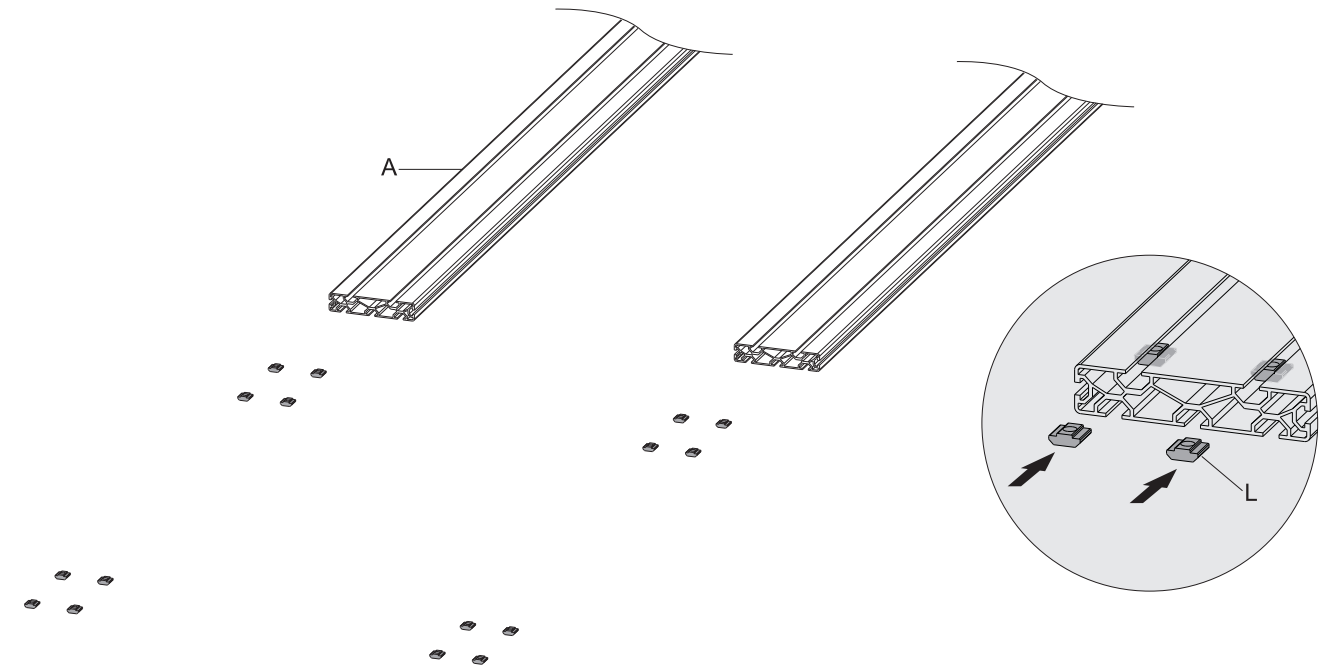

Note: Ensure the gap between the nuts halves on both sides are equal.

3. Install the End Cap

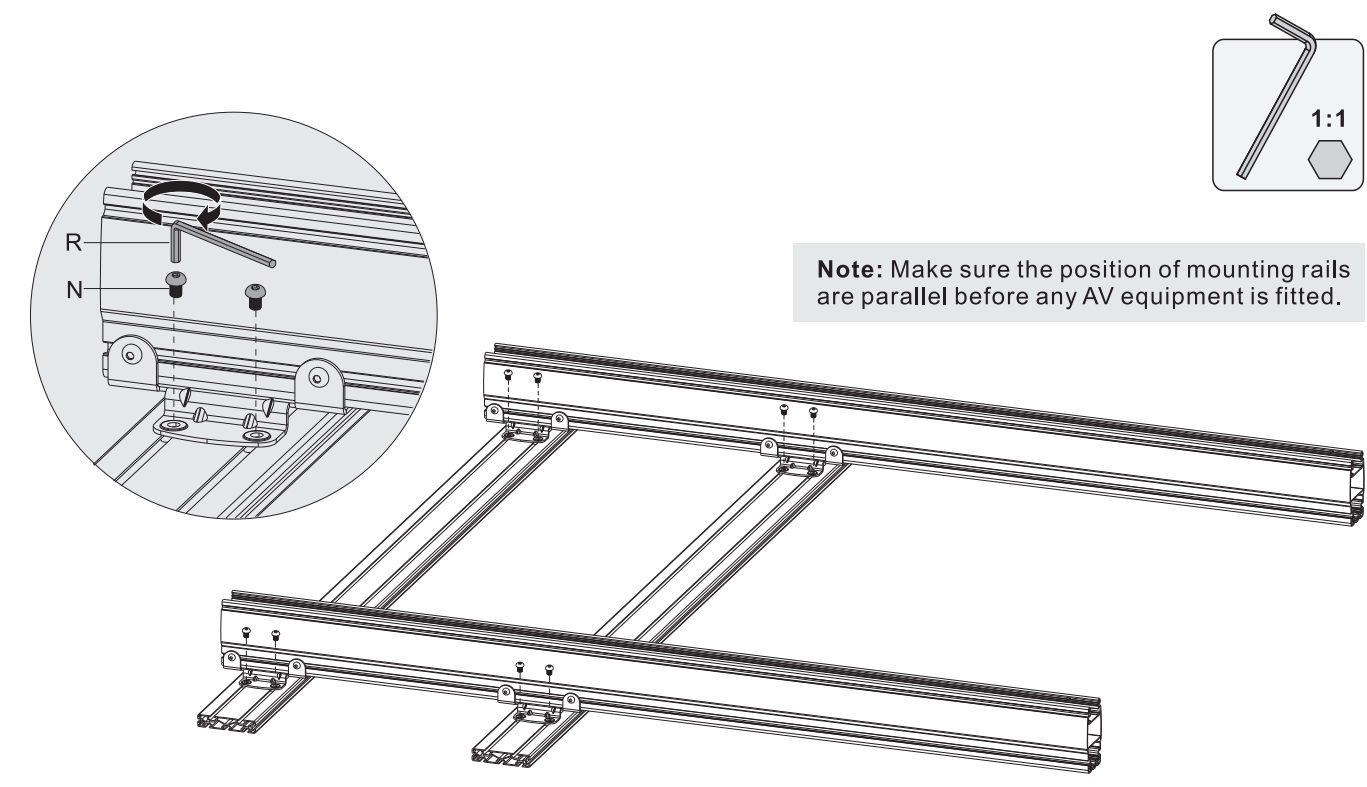

4. Assemble the Base

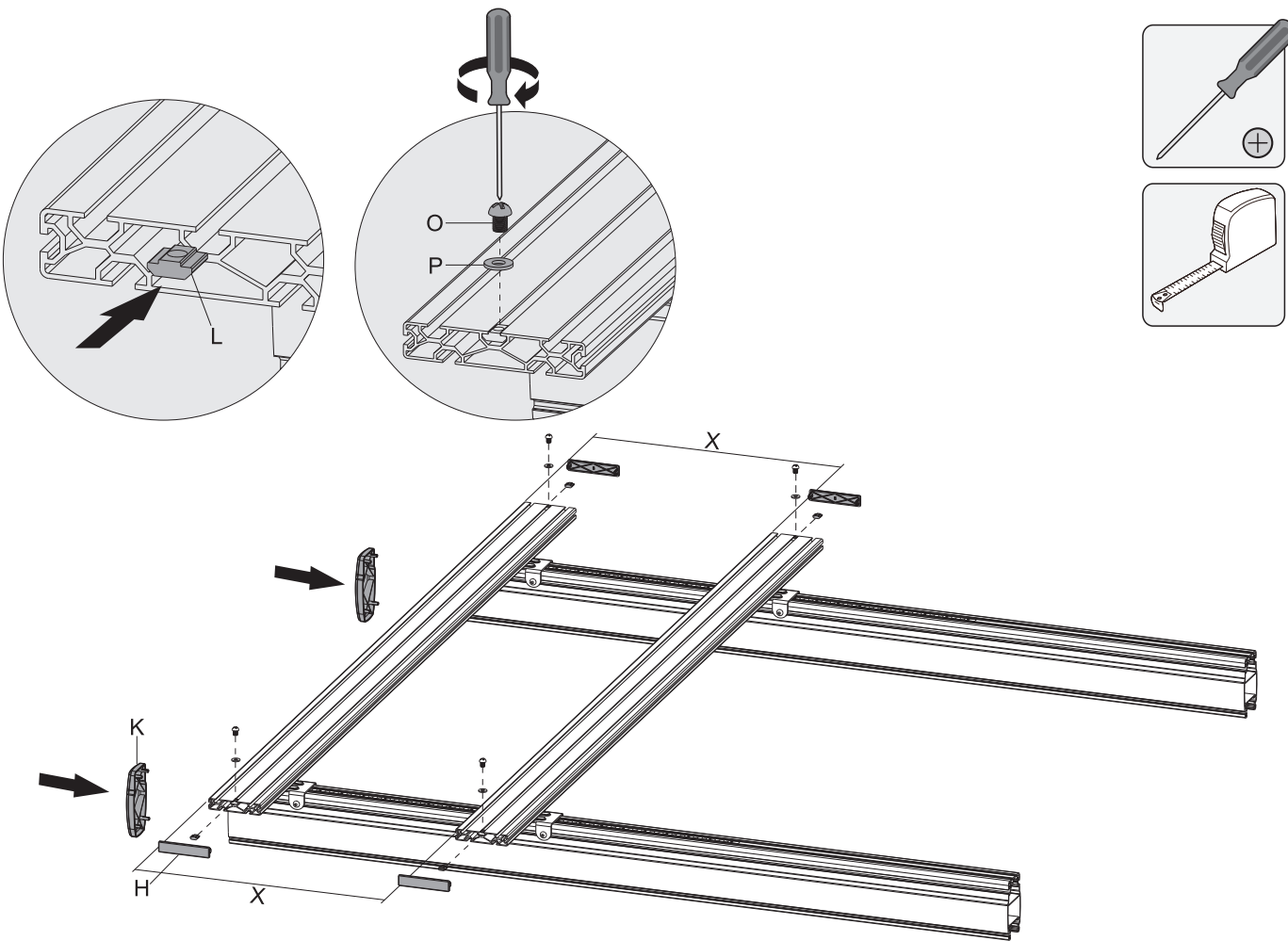

4. Assemble the Base

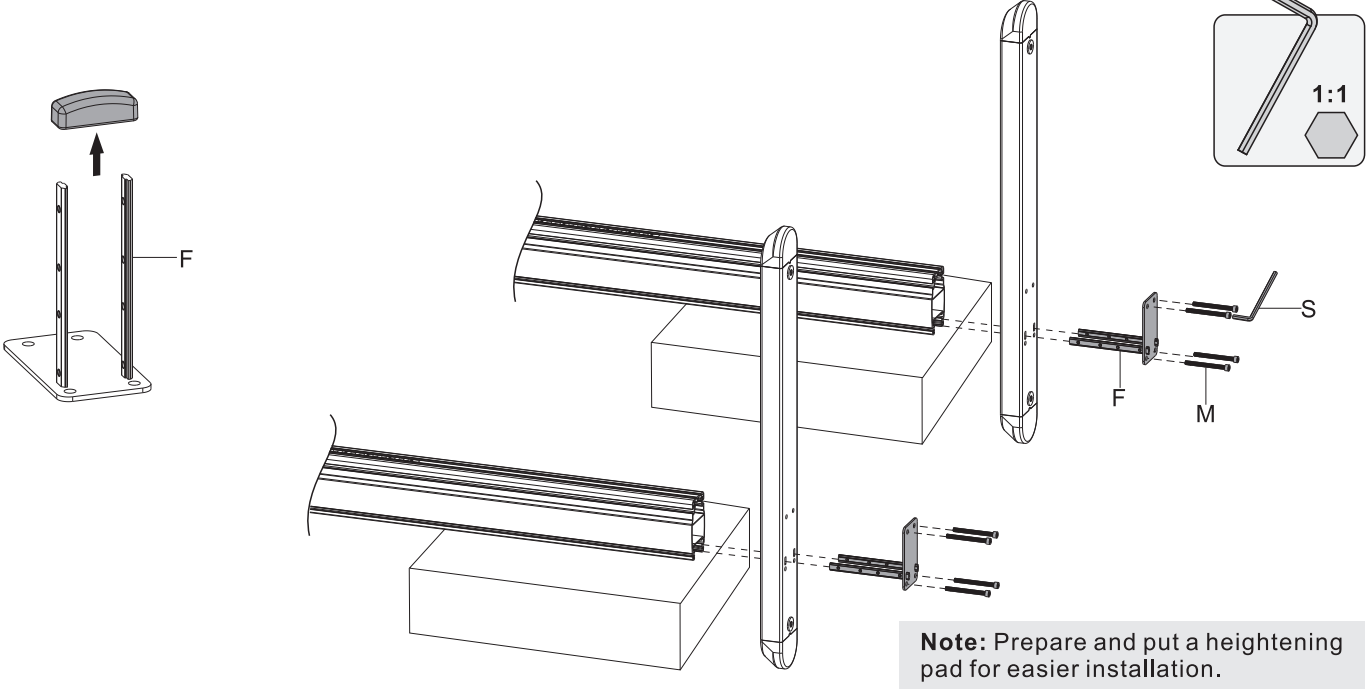

5. Lock the Brakes

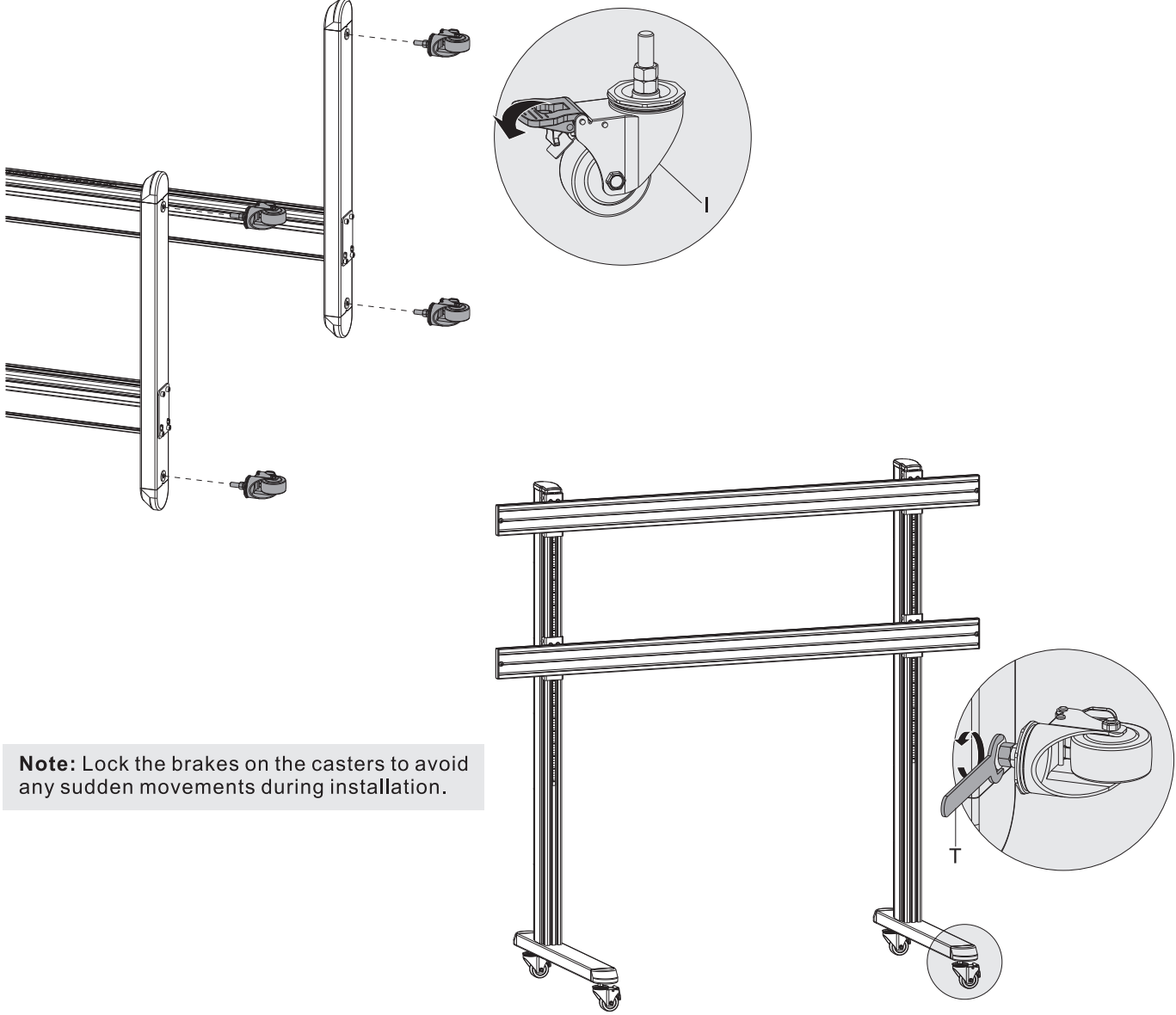

5. Attach TV Bracket

With the arrow pointing up.

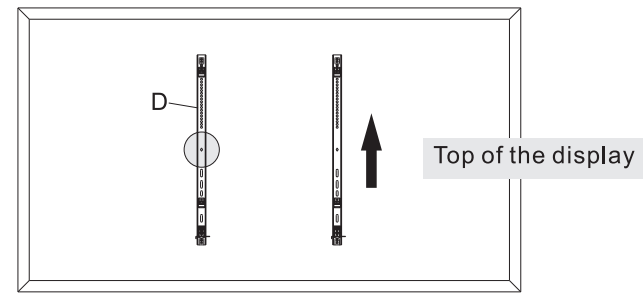
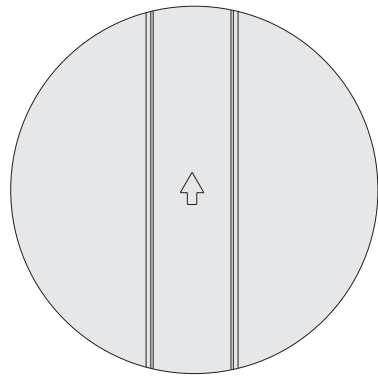

5a. Attach TV Bracket to Flat Back Screen

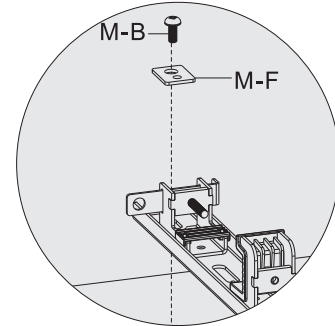
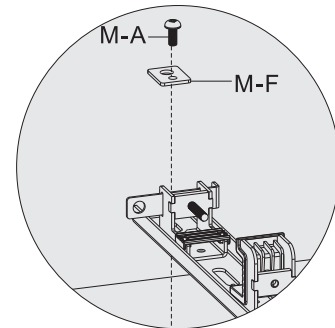
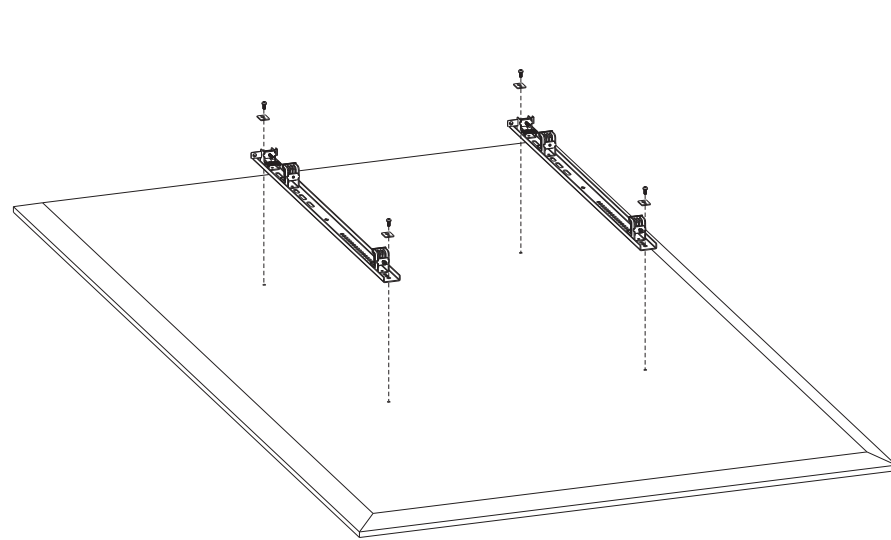
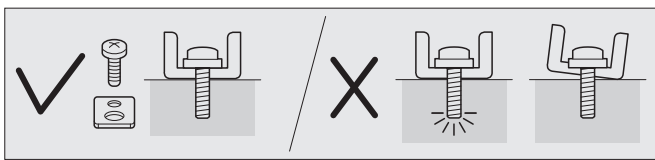

M-A			M-B		
M-F					

5b. Attach TV Bracket to Irregular Back Screen

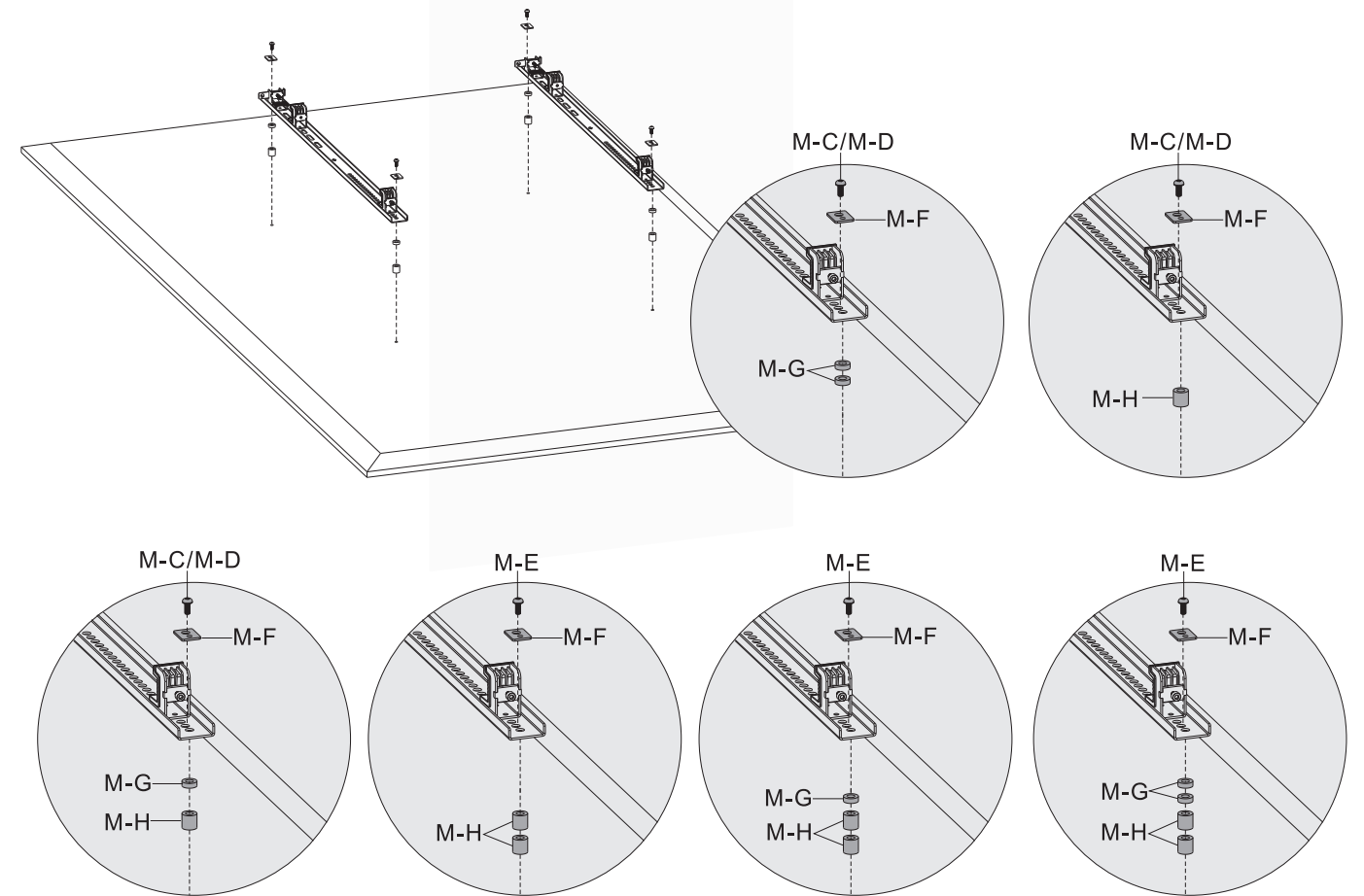
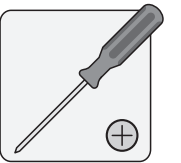
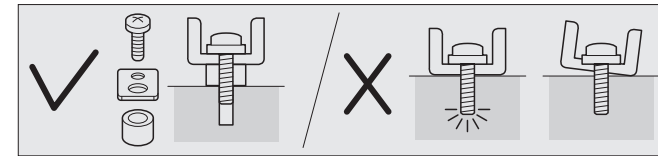

M-C			M-D		
M-E			M-F		
M-G			M-H		

Note: Choose the appropriate screws, washers and spacers (if necessary) according to the type of screen.
 • Position the adapter brackets as close as possible to the center of the display.
 • Screw the adapter brackets onto the display.

⚠ Tighten all screws but do not over tighten.

6. Hang the Screen

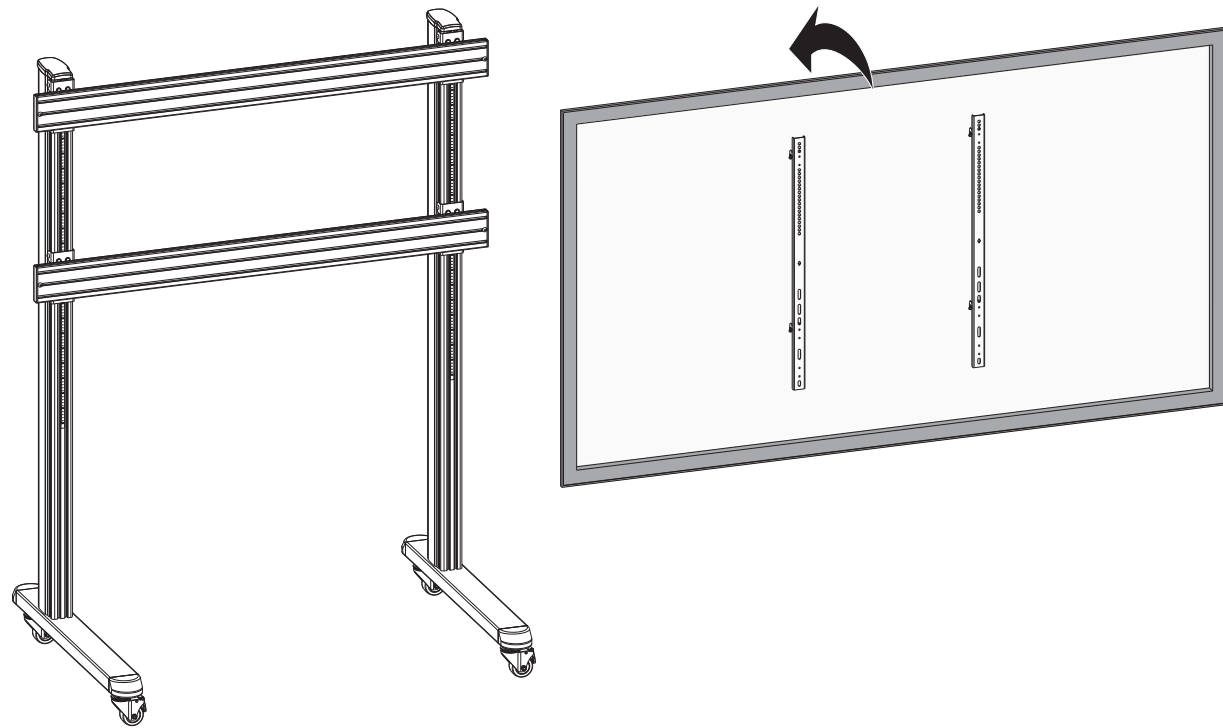

7. Level Adjustment

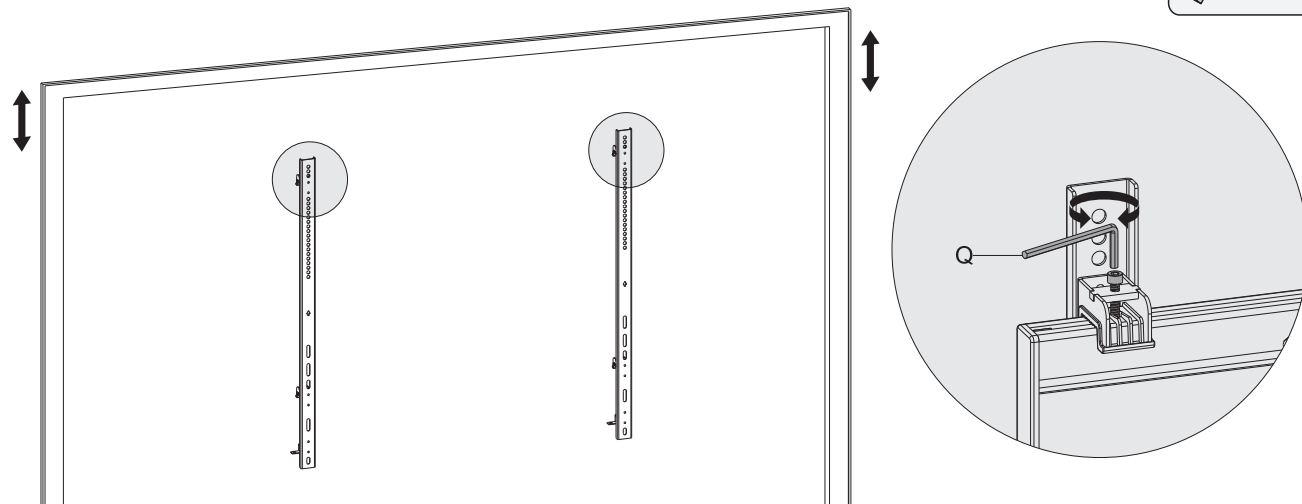
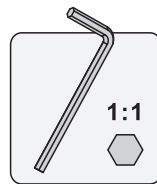

8. Secure with Padlock

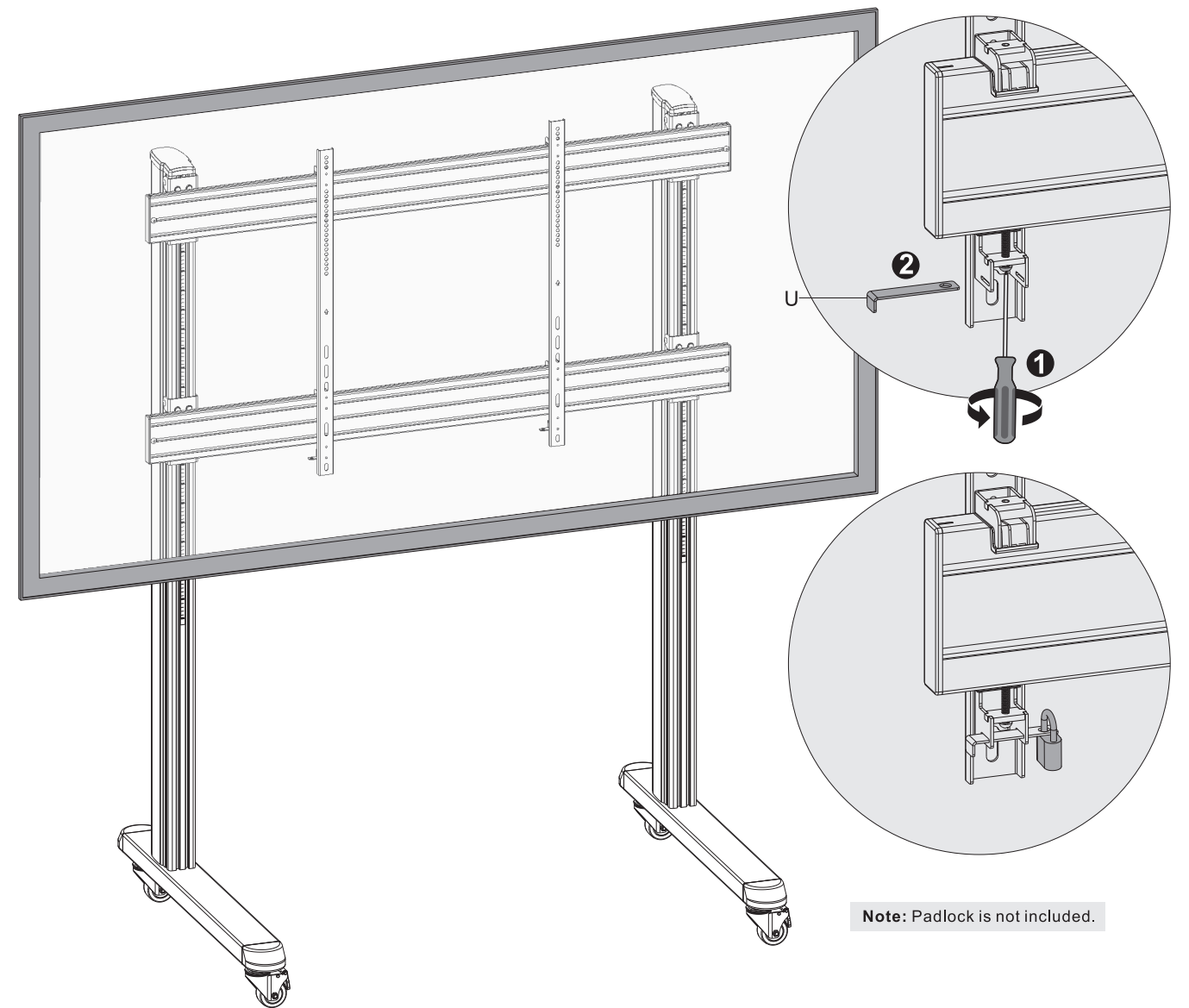
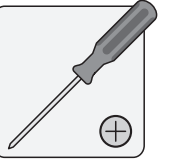

Note: Padlock is not included.